

NX-series Safety Control Units

NX-SL/SI/SO

CSM_NX-SL_SI_SO_E_2_1

Integration of Safety into Machine Automation Enables Simple, Flexible System Configuration.

- EN ISO13849-1 (PLe/Safety Category4), IEC 61508 (SIL3) certified.
- One connection using Safety over EtherCAT (FSoE) * protocol enables flexible configuration by mixing the Safety Units with standard NX I/O.
- Hardware and safety circuits can be configured using the Sysmac Studio (Ver. 1.07)



* Safety over EtherCAT (FSoE): The open protocol Safety over EtherCAT (abbreviated with FSoE "FailSafe over EtherCAT") defines a safety related communication layer for EtherCAT. Safety over EtherCAT meets the requirements of IEC 61508 SIL 3 and enables the transfer of safe and standard information on the same communication system without limitations with regard to transfer speed and cycle time.

Features

- Integrated safety into machine automation possible by connecting with the NX-series EtherCAT Coupler.
- The Safety CPU Unit controls up to 128 Safety I/O Units.
- 4 or 8 points per Safety Input Unit. The 4-point Safety Input Unit can be directly connected with OMRON Non-contact Switches and Singlebeam Sensors.
- 2 or 4 points per Safety Output Unit. The 2-point Safety Output Unit is characterized by large output breaking current of 2.0 A.
- The Safety Units can be freely allocated in any combination with standard NX I/O.
- Compliant with IEC61131-3
- Safety programs can be standardized and reused efficiently by using POUs for design and operation.

Sysmac is a trademark or registered trademark of OMRON Corporation in Japan and other countries for OMRON factory automation products. EtherCAT® is registered trademark and patented technology, licensed by Beckhoff Automation GmbH, Germany. Safety over EtherCAT® is registered trademark and patented technology, licensed by Beckhoff Automation GmbH, Germany. Other company names and product names in this document are the trademarks or registered trademarks of their respective companies.

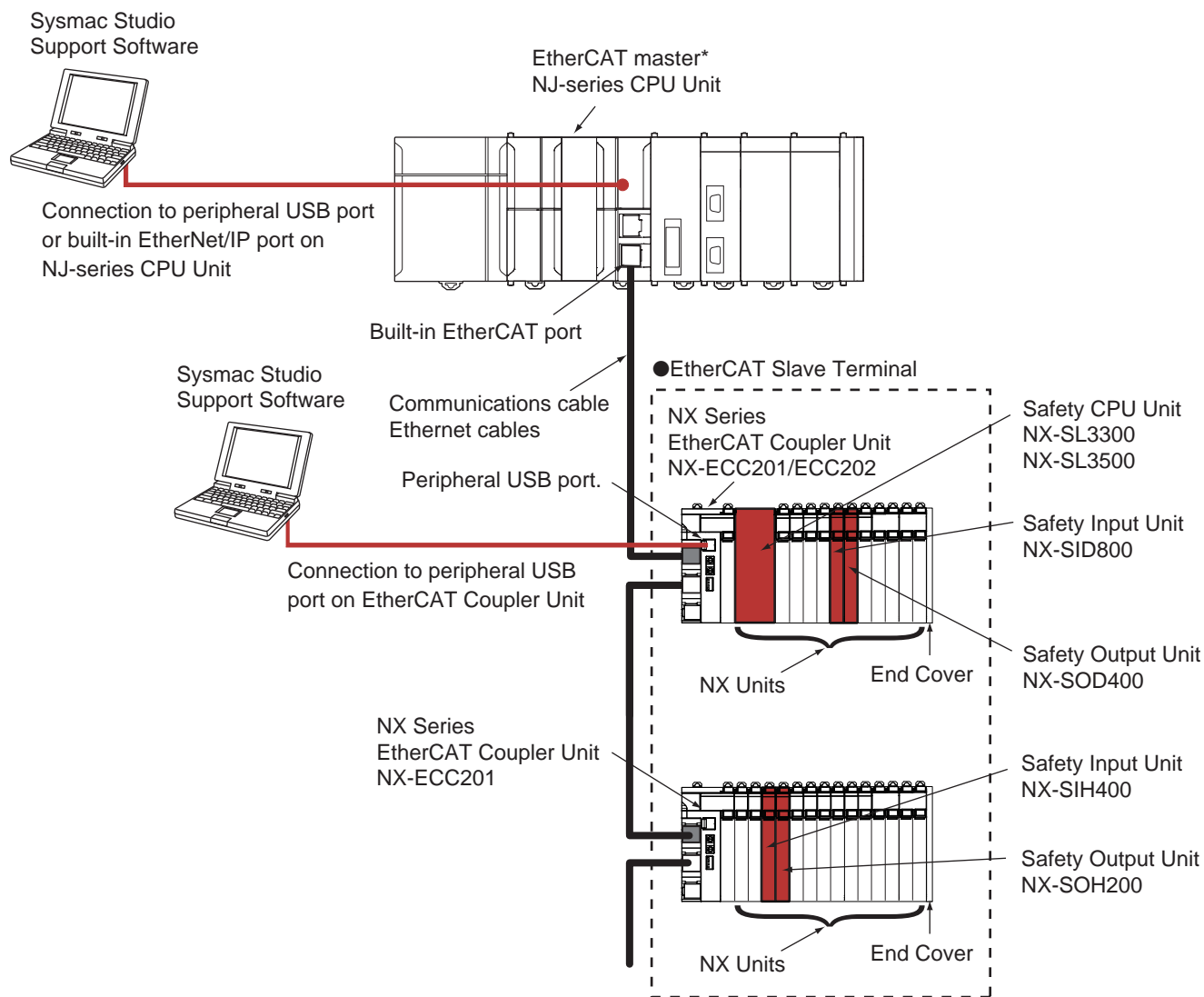

System Configuration





* OMRON CJ1W-NC□81/□82 Position Control Units cannot be connected to the EtherCAT Slave Terminal even though they support EtherCAT.

Ordering Information

Safety CPU Unit

Unit type	Appearance	Specifications				Model
		Maximum number of safety I/O points	Program capacity	Number of safety master connections	I/O refreshing method	
Safety CPU Unit		256 points	512KB	32	Free-Run refreshing	NX-SL3300
		1024 points	2048KB	128	Free-Run refreshing	NX-SL3500



Safety Input Units

Unit type	Appearance	Specifications							Model
		Number of safety input points	Number of test output points	Internal I/O common	Rated input voltage	OMRON special safety input devices	Number of safety slave connections	I/O refreshing method	
Safety Input Units		4 points	2 points	Sinking inputs (PNP)	24 VDC	Can be connected. *	1	Free-Run refreshing	NX-SIH400
		8 points	2 points	Sinking inputs (PNP)	24 VDC	Cannot be connected.	1	Free-Run refreshing	NX-SID800

* The following OMRON special safety input devices can be connected directly without a special controller.
For detail of connectable OMRON special safety input devices, refer to NX-series Safety Control Units User's Manual(No.Z930-E1).

Type	Model and corresponding PL and safety category
OMRON Single-beam Safety Sensors	E3ZS and E3FS
OMRON Non-contact Door Switches	D40Z D40A
OMRON Safety Mats	UM
OMRON Safety Edges	SGE (4-wire connection)

Safety Output Units

Unit type	Appearance	Specifications						Model
		Number of safety output points	Internal I/O common	Maximum load current	Rated voltage	Number of safety slave connections	I/O refreshing method	
Safety Output Units		2 points	Sourcing outputs (PNP)	2.0 A/point, 4.0 A/Unit at 40°C, and 2.5 A/Unit at 55°C The maximum load current depends on the installation orientation and ambient temperature.	24 VDC	1	Free-Run refreshing	NX-SOH200
		4 points	Sourcing outputs (PNP)	0.5 A/point and 2.0 A/Unit	24 VDC	1	Free-Run refreshing	NX-SOD400

Option

Product Name	Specification	Model
Unit/Terminal Block Coding Pins	For 10 Units (Terminal Block: 30 pins, Unit: 30 pins)	NX-AUX02

Product name	Specification				Model
	No. of terminals	Terminal number indications	Ground terminal mark	Terminal current capacity	
Terminal Block	8	A/B	None	10A	NX-TBA082
	16	A/B	None	10A	NX-TBA162

Accessories

Not included.

Specifications

Regulations and Standards

Certification body	Standards
TÜV Rheinland *	<ul style="list-style-type: none"> • EN ISO 13849-1: 2008 + AC: 2009 • EN ISO 13849-2: 2012 • IEC 61508 parts 1-7: 2010 • EN 62061: 2005 • EN 61131-2: 2007 • EN ISO 13850: 2008 • EN 60204-1: 2006 + A1: 2009 + AC: 2010 • EN 61000-6-2: 2005 • EN 61000-6-4: 2007 • NFPA 79: 2012 • ANSI RIA 15.06-1999 • ANSI B11.19-2010 • UL1998 • IEC 61326-3-1: 2008
UL	cULus: Listed (UL508) and ANSI/ISA 12.12.01

* Certification was received for applications in which OMRON FSoE devices are connected to each other.

The NX-series Safety Control Units allow you to build a safety control system that meets the following standards.

- Requirements for SIL 3 (Safety Integrity Level 3) in IEC 61508, EN 62061, Safety Standard for Safety Instrumented Systems (Functional Safety of Electrical/Electronic/Programmable Electronic Safety-related Systems)
- Requirements for PLe (Performance Level e) and for safety category 4 in EN ISO13849-1



The NX-series Safety Control Units are also registered for C-Tick and KC compliance.

General Specification

Item	Specification	
Enclosure	Mounted in a panel (open)	
Grounding method	Ground to 100 Ω or less.	
Operating environment	Ambient operating temperature	0 to 55°C (The upper limit of the ambient operating temperature is restricted by the installation orientation.)
	Ambient operating humidity	10% to 95% (with no condensation or icing)
	Atmosphere	Must be free from corrosive gases.
	Ambient storage temperature	-25 to 70°C (with no condensation or icing)
	Altitude	2,000 m max.
	Pollution degree	2 or less: Conforms to JIS B3502 and IEC 61131-2.
	Noise immunity	Conforms to IEC 61131-2. 2 kV on power supply line (Conforms to IEC 61000-4-4.)
	Insulation class	Class III (SELV)
	Overvoltage category	Category II: Conforms to JIS B3502 and IEC 61131-2.
	EMC immunity level	Zone B
	Vibration resistance	Conforms to IEC 60068-2-6. 5 to 8.4 Hz with 3.5-mm amplitude, 8.4 to 150 Hz, acceleration of 9.8 m/s ² , 100 minutes each in X, Y, and Z directions (10 sweeps of 10 min each = 100 min total)
	Shock resistance	Conforms to IEC 60068-2-27. 147 m/s ² , 3 times each in X, Y, and Z directions
	Insulation resistance	20 MΩ between isolated circuits (at 100 VDC)
Dielectric strength	510 VAC for 1 min between isolated circuits, leakage current: 5 mA max.	
Installation method	DIN Track (IEC 60715 TH35-7.5/TH35-15)	
Applicable standards	IEC 61508: 2010 SIL 3, EN 62061: 2005 SIL CL3 EN ISO 13849-1, 13849-2: 2008 PL e/Safety Category 4 UL 1998 cULus: Listed UL508, ANSI/ISA 12.12.01 EN 61131-2, C-Tick, KC: KC Registration	

Specifications of Individual Units

Safety CPU Unit NX-SL3300/SL3500

Unit name	Safety CPU Unit	
Model	NX-SL3300	NX-SL3500
Maximum number of safety I/O points	256 points	1024 points
Program capacity	512 KB	2048 KB
Number of safety master connections	32	128
I/O refreshing method	Free-Run refreshing	Free-Run refreshing
External connection terminals	None	None
Indicators	FS indicator, VALID indicator, DEBUG indicator, TS indicator, and RUN indicator 	FS indicator, VALID indicator, DEBUG indicator, TS indicator, and RUN indicator 
Dimensions	30 × 100 × 71 mm (W × H × D)	
I/O power supply method	Not supplied.	
Current capacity of I/O power supply terminals	No I/O power supply terminals	
NX Unit power consumption	0.90 W max.	
Current consumption from I/O power supply	No consumption	
Weight	75 g max.	
Installation orientation and restrictions	Installation orientation: 6 possible orientations Restrictions: None	

Safety Input Units NX-SIH400/SID800

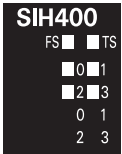
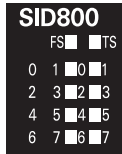
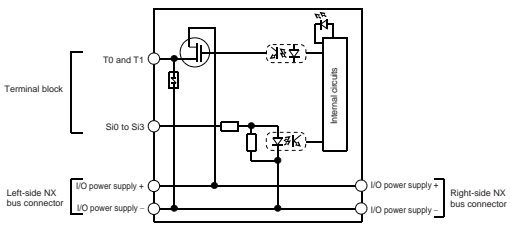
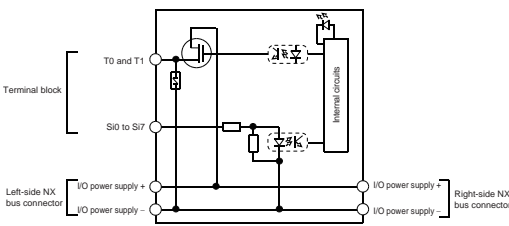
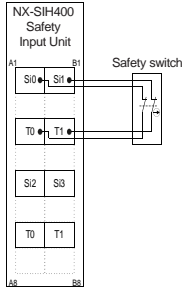
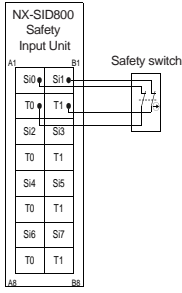
Unit name	Safety Input Unit	
Model	NX-SIH400	NX-SID800
Number of safety input points	4 points	8 points
Number of test output points	2 points	2 points
Internal I/O common	PNP (sinking inputs)	
Rated input voltage	24 VDC (20.4 to 28.8 VDC)	
OMRON special safety input devices	Can be connected.	Cannot be connected.
Number of safety slave connections	1	
I/O refreshing method	Free-Run refreshing	
External connection terminals	Screwless clamping terminal block (8 terminals)	Screwless clamping terminal block (16 terminals)
Indicators	TS indicator, FS indicator, input indicators (yellow), and input error indicators (red) 	TS indicator, FS indicator, input indicators (yellow), and input error indicators (red) 
Safety input current	4.5 mA typical	3.0 mA typical
Safety input ON voltage	11 VDC min.	15 VDC min.
Safety input OFF voltage/OFF current	5 VDC max., 1 mA max.	
Test output type	Sourcing outputs (PNP)	
Test output load current	25 mA max.	50 mA max.
Test output residual voltage	1.2 V max. (Between IOV and all output terminals)	
Test output leakage current	0.1 mA max.	
Dimensions	12 × 100 × 71 mm (W × H × D)	
Isolation method	Photocoupler isolation	
Insulation resistance	20 MΩ min. between isolated circuits (at 100 VDC)	
Dielectric strength	510 VAC for 1 min between isolated circuits, leakage current: 5 mA max.	
I/O power supply method	Power supplied from the NX bus	
Current capacity of I/O power supply terminals	No applicable terminals.	
NX Unit power consumption	0.70 W max.	0.75 W max.
Current consumption from I/O power supply	20 mA max.	
Weight	70 g max.	
Circuit layout		
Terminal connection diagram	<p>Si0 to Si3: Safety input terminals T0 and T1: Test output terminals</p>  <p>Refer to User's manual (Z930-E1) for details.</p>	<p>Si0 to Si7: Safety input terminals T0 and T1: Test output terminals</p>  <p>Refer to User's manual (Z930-E1) for details.</p>
Installation orientation and restrictions	Installation orientation: 6 possible orientations. Restrictions: Maximum ambient temperature is 50°C for any orientation other than upright installation.	
Protective functions	Overvoltage protection circuit and short detection (test outputs)	

Safety Output Units NX-SOH200/SOD400

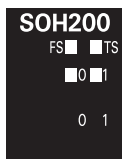
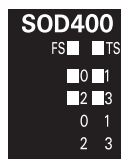
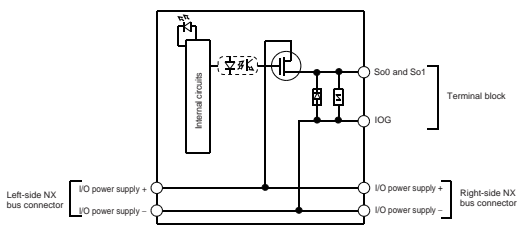
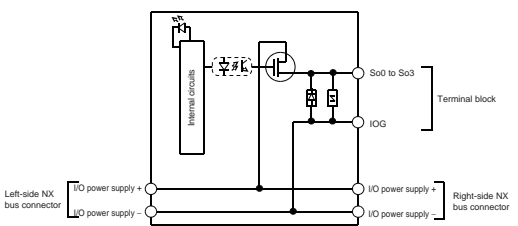
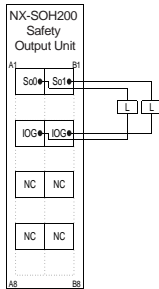
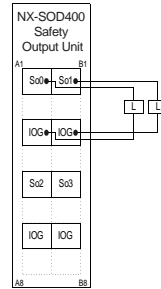
Unit name	Safety Output Unit	
Model	NX-SOH200	NX-SOD400
Number of safety output points	2 points	4 points
Internal I/O common	PNP (sourcing outputs)	
Maximum load current	2.0 A/point 4.0 A/Unit at 40°C 2.5 A/Unit at 55°C The maximum load current depends on the installation orientation and ambient temperature	0.5 A/point and 2.0 A/Unit
Rated voltage	24 VDC (20.4 to 28.8 VDC)	
Number of safety slave connections	1	
I/O refreshing method	Free-Run refreshing	
External connection terminals	Screwless clamping terminal block (8 terminals)	
Indicators	TS indicator, FS indicator, output indicators (yellow), and output error indicators (red) 	TS indicator, FS indicator, output indicators (yellow), and output error indicators (red) 
Safety output ON residual voltage	1.2 V max. (Between IOV and all output terminals)	
Safety output OFF residual voltage	2 V max. (Between IOG and all output terminals)	
Safety output leakage current	0.1 mA max.	
Dimensions	12 × 100 × 71 mm (W × H × D)	
Isolation method	Photocoupler isolation	
Insulation resistance	20 MΩ min. between isolated circuits (at 100 VDC)	
Dielectric strength	510 VAC for 1 min between isolated circuits, leakage current: 5 mA max.	
I/O power supply method	Power supplied from the NX bus	
Current capacity of I/O power supply terminals	IOG: 2 A max./terminal	IOG (A3 and B3): 2 A max./terminal IOG (A7 and B7): 0.5 A max./terminal
NX Unit power consumption	0.70 W max.	0.75 W max.
Current consumption from I/O power supply	40 mA max.	60 mA max.
Weight	65 g max.	
Circuit layout		
Terminal connection diagram	So0 and So1: Safety output terminals IOG: I/O power supply 0 V 	So0 to So3: Safety output terminals IOG: I/O power supply 0 V 
	Refer to User's manual (Z930-E1) for details.	Refer to User's manual (Z930-E1) for details.

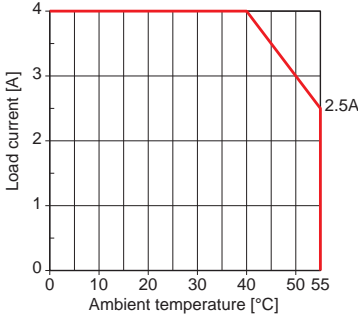
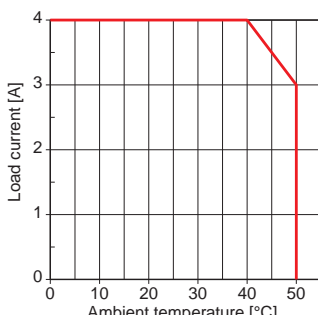
Unit name	Safety Output Unit	
Model	NX- SOH200	NX-SOD400
Installation orientation and restrictions	<p>Installation orientation: 6 possible orientations</p> <p>Restrictions: For upright installation, the ambient temperature is restricted as shown below depending on the total Unit load current.</p>  <p>For all installation orientations other than upright installation, the ambient temperature is restricted as shown below according to the total Unit load current.</p> 	
Protective functions	Overvoltage protection circuit and short detection	

Version Information

The combinations that can be used of the unit versions of the Safety Control Units, NJ-series CPU Units, and NX-series EtherCAT Coupler Unit, and the version of the Sysmac Studio

NX Unit		Corresponding unit versions/version		
Model number	Unit version	EtherCAT Coupler Unit NX-ECC201/EC202 *	NJ-series CPU Units (NJ501-□□□□) (NJ301-□□□□)	Sysmac Studio
NX-SL3300	1.0 or later	1.1 or later	1.06 or later	1.07 or later
NX-SIH400				
NX-SID800				
NX-SOD400				
NX-SOH200	1.0	1.2 or later	1.07 or later	1.08 or later
NX-SL3500				

* For the NX-ECC202, there is no unit version of 1.1 or earlier.

External Interface

Safety CPU Unit

NX-SL3300/SL3500

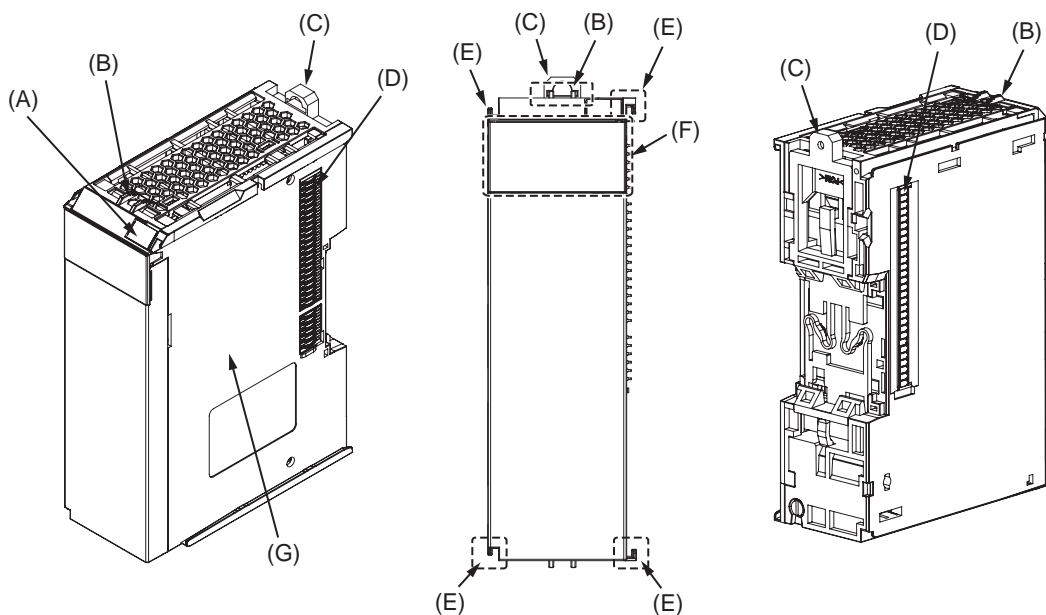

Letter	Item	Specification
A	Marker attachment locations	The locations where markers are attached. The markers made by OMRON are installed for the factory setting. Commercially available markers can also be installed. For details, refer to User's Manual (Z930-E1).
B	Protrusions for removing the Unit	The protrusions to hold when removing the Unit.
C	DIN Track mounting hooks	These hooks are used to mount the NX Unit to a DIN Track.
D	NX bus connector	This is the NX-series bus connector. It is used to connect an NX-series Safety I/O Unit or other NX Unit.
E	Unit hookup guides	These guides are used to connect two Units.
F	Indicators	The indicators show the current operating status of the NX Unit or signal I/O status. Refer to User's Manual (Z930-E1).
G	Unit specifications	The specifications of the NX Unit are given here.

Safety Input Unit NX-SIH400/SID800
 Safety Output Unit NX-SOH200/SOD400

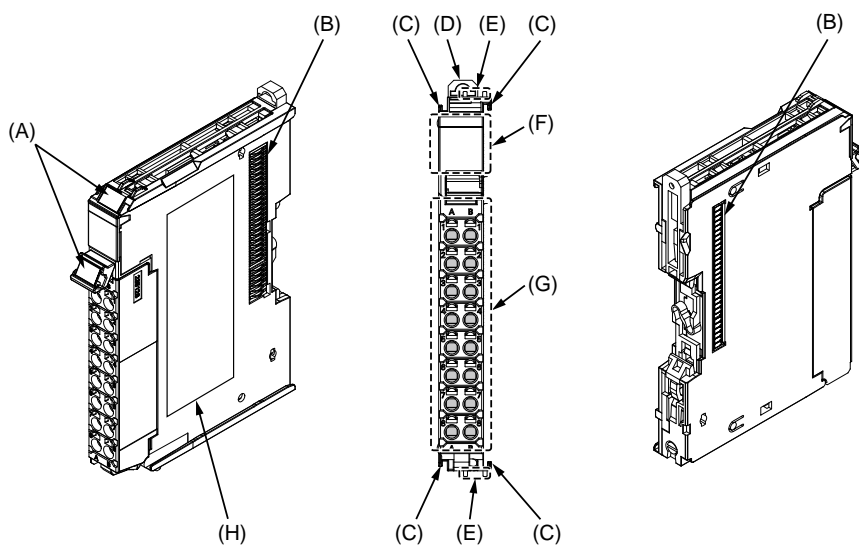

Letter	Item	Specification
A	Marker attachment locations	The locations where markers are attached. The markers made by OMRON are installed for the factory setting. Commercially available markers can also be installed. For details, refer to User's Manual (Z930-E1).
B	NX bus connector	This is the NX-series bus connector. Connect this connector to another Unit, such as the NX-series Safety CPU Unit or a Safety I/O Unit.
C	Unit hookup guides	These guides are used to connect two Units.
D	DIN Track mounting hooks	These hooks are used to mount the NX Unit to a DIN Track.
E	Protrusions for removing the Unit	The protrusions to hold when removing the Unit.
F	Indicators	The indicators show the current operating status of the NX Unit or signal I/O status. Refer to User's Manual (Z930-E1).
G	Terminal block	The terminal block is used to connect to external devices. It connects the safety outputs. The number of terminals depends on the NX Unit.
H	Unit specifications	The specifications of the NX Unit are given here.

Terminal Blocks

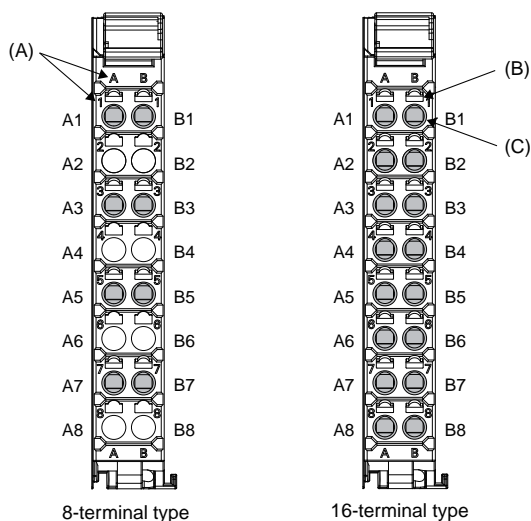

Letter	Item	Specification
(A)	Terminal number indications	The terminal numbers are given by column letters A and B, and row numbers 1 to 8. The combination of the column and row gives the terminal numbers from A1 to A8 and B1 to B8. The terminal number indicators are the same regardless of the number of terminals on the terminal block, as shown above.
(B)	Release holes	Insert a flat-blade screwdriver into these holes to connect and remove the wires.
(C)	Terminal holes	The wires are inserted into these holes.

Applicable Terminal Blocks for Each Unit Model

Unit model number	Terminal Blocks				
	Model	No. of terminals	Terminal number indications	Ground terminal mark	Terminal current capacity
NX-SIH400	NX-TBA082	8	A/B	None	10A
NX-SID800	NX-TBA162	16	A/B	None	10A
NX-SOH200	NX-TBA082	8	A/B	None	10A
NX-SOD400	NX-TBA082	8	A/B	None	10A

Applicable Wires

Using Ferrules

If you use ferrules, attach the twisted wires to them.

Observe the application instructions for your ferrules for the wire stripping length when attaching ferrules.

Always use one-pin ferrules. Do not use two-pin ferrules.

The applicable ferrules, wires, and crimping tool are given in the following table.

Terminal types	Manufacturer	Ferrule model number	Applicable wire (mm ² (AWG))	Crimping tool	
Terminals other than ground terminals	Phoenix Contact	AI0,34-8	0.34 (#22)	Phoenix Contact (The figure in parentheses is the applicable wire size.) CRIMPFOX 6 (0.25 to 6 mm ² , AWG24 to 10)	
		AI0,5-8	0.5 (#20)		
		AI0,5-10			
		AI0,75-8	0.75 (#18)		
		AI0,75-10			
		AI1,0-8	1.0 (#18)		
		AI1,0-10			
		AI1,5-8	1.5 (#16)		
Ground terminals	Phoenix Contact	AI1,5-10			
		AI2,5-10	2.0 *		
Terminals other than ground terminals	Weidmuller	H0.14/12	0.14 (#26)		Weidmuller (The figure in parentheses is the applicable wire size.) PZ6 Roto (0.14 to 6 mm ² , AWG 26 to 10)
		H0.25/12	0.25 (#24)		
		H0.34/12	0.34 (#22)		
		H0.5/14	0.5 (#20)		
		H0.5/16			
		H0.75/14	0.75 (#18)		
		H0.75/16			
		H1.0/14	1.0 (#18)		
		H1.0/16			
		H1.5/14	1.5 (#16)		
			H1.5/16		

* Some AWG 14 wires exceed 2.0 mm² and cannot be used in the screwless clamping terminal block.

When you use any ferrules other than those in the above table, crimp them to the twisted wires so that the following processed dimensions are achieved.

Finished Dimensions of Ferrules

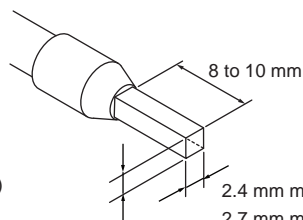

1.6 mm max. (except ground terminals)

2.0 mm max. (ground terminals)

2.4 mm max. (except ground terminals)

2.7 mm max. (ground terminals)

Using Twisted Wires/Solid Wires

If you use the twisted wires or the solid wires, the applicable wire range and conductor length (stripping length) are as follows.

Use the twisted wires to connect the ground wire to a ground of 100 Ω or less. Do not use the solid wires.

Terminal types	Applicable wires	Conductor length (stripping length)
Ground terminals	2.0 mm ²	9 to 10 mm
Terminals other than ground terminals	0.08 to 1.5 mm ² AWG28 to 16	8 to 10 mm

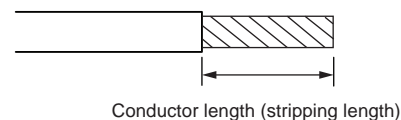

Dimensions

Safety CPU Unit NX-SL3300/SL3500

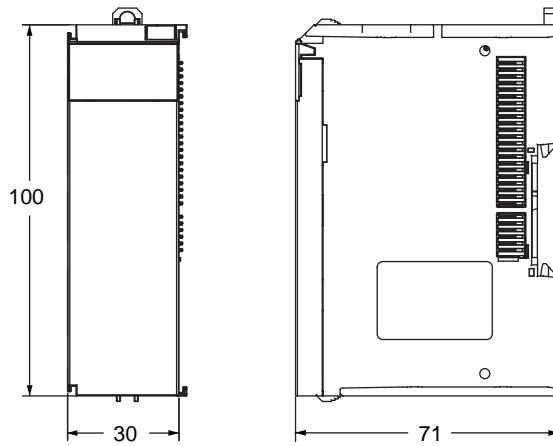

Safety Input Units NX-SIH400/SID800 Safety Output Units NX-SOH200/SOD400

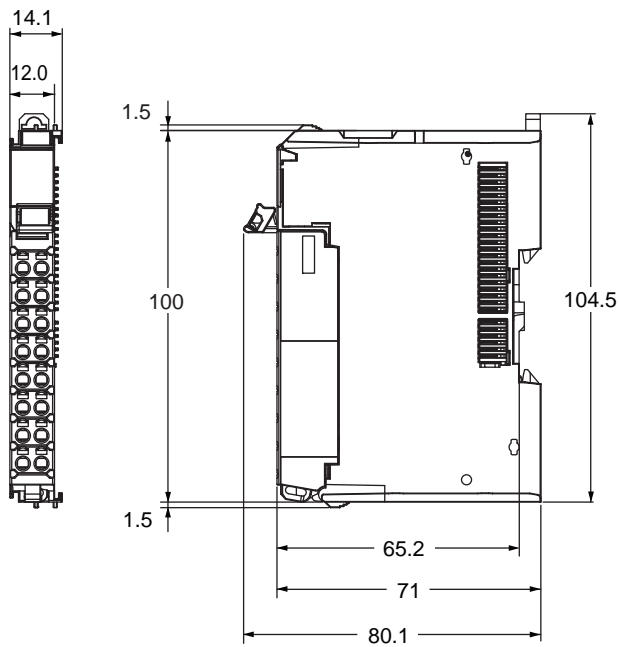

Related Manuals

Cat. No.	Model number	Manual name	Application	Description
Z930	NX-SL□□□□ NX-SI□□□□ NX-SO□□□□	NX-series Safety Control Unit User's Manual	Learning how to use NX-series Safety Control Units.	Describes the hardware, setup methods, and functions of the NX-series Safety Control Units.
Z931	NX-SL□□□□	NX-series Safety Control Unit Instructions Reference Manual	Learning about the specifications of instructions for the Safety CPU Unit.	Describes the instructions for the Safety CPU Unit. When programming, use this manual together with the <i>NX-series Safety Control Units User's Manual</i> (Cat. No. Z930).

Terms and Conditions Agreement

Read and understand this catalog.

Please read and understand this catalog before purchasing the products. Please consult your OMRON representative if you have any questions or comments.

Warranties.

(a) Exclusive Warranty. Omron's exclusive warranty is that the Products will be free from defects in materials and workmanship for a period of twelve months from the date of sale by Omron (or such other period expressed in writing by Omron). Omron disclaims all other warranties, express or implied.

(b) Limitations. OMRON MAKES NO WARRANTY OR REPRESENTATION, EXPRESS OR IMPLIED, ABOUT NON-INFRINGEMENT, MERCHANTABILITY OR FITNESS FOR A PARTICULAR PURPOSE OF THE PRODUCTS. BUYER ACKNOWLEDGES THAT IT ALONE HAS DETERMINED THAT THE PRODUCTS WILL SUITABLY MEET THE REQUIREMENTS OF THEIR INTENDED USE.

Omron further disclaims all warranties and responsibility of any type for claims or expenses based on infringement by the Products or otherwise of any intellectual property right. (c) Buyer Remedy. Omron's sole obligation hereunder shall be, at Omron's election, to (i) replace (in the form originally shipped with Buyer responsible for labor charges for removal or replacement thereof) the non-complying Product, (ii) repair the non-complying Product, or (iii) repay or credit Buyer an amount equal to the purchase price of the non-complying Product; provided that in no event shall Omron be responsible for warranty, repair, indemnity or any other claims or expenses regarding the Products unless Omron's analysis confirms that the Products were properly handled, stored, installed and maintained and not subject to contamination, abuse, misuse or inappropriate modification. Return of any Products by Buyer must be approved in writing by Omron before shipment. Omron Companies shall not be liable for the suitability or unsuitability or the results from the use of Products in combination with any electrical or electronic components, circuits, system assemblies or any other materials or substances or environments. Any advice, recommendations or information given orally or in writing, are not to be construed as an amendment or addition to the above warranty.

See <http://www.omron.com/global/> or contact your Omron representative for published information.

Limitation on Liability; Etc.

OMRON COMPANIES SHALL NOT BE LIABLE FOR SPECIAL, INDIRECT, INCIDENTAL, OR CONSEQUENTIAL DAMAGES, LOSS OF PROFITS OR PRODUCTION OR COMMERCIAL LOSS IN ANY WAY CONNECTED WITH THE PRODUCTS, WHETHER SUCH CLAIM IS BASED IN CONTRACT, WARRANTY, NEGLIGENCE OR STRICT LIABILITY.

Further, in no event shall liability of Omron Companies exceed the individual price of the Product on which liability is asserted.

Suitability of Use.

Omron Companies shall not be responsible for conformity with any standards, codes or regulations which apply to the combination of the Product in the Buyer's application or use of the Product. At Buyer's request, Omron will provide applicable third party certification documents identifying ratings and limitations of use which apply to the Product. This information by itself is not sufficient for a complete determination of the suitability of the Product in combination with the end product, machine, system, or other application or use. Buyer shall be solely responsible for determining appropriateness of the particular Product with respect to Buyer's application, product or system. Buyer shall take application responsibility in all cases.

NEVER USE THE PRODUCT FOR AN APPLICATION INVOLVING SERIOUS RISK TO LIFE OR PROPERTY OR IN LARGE QUANTITIES WITHOUT ENSURING THAT THE SYSTEM AS A WHOLE HAS BEEN DESIGNED TO ADDRESS THE RISKS, AND THAT THE OMRON PRODUCT(S) IS PROPERLY RATED AND INSTALLED FOR THE INTENDED USE WITHIN THE OVERALL EQUIPMENT OR SYSTEM.

Programmable Products.

Omron Companies shall not be responsible for the user's programming of a programmable Product, or any consequence thereof.

Performance Data.

Data presented in Omron Company websites, catalogs and other materials is provided as a guide for the user in determining suitability and does not constitute a warranty. It may represent the result of Omron's test conditions, and the user must correlate it to actual application requirements. Actual performance is subject to the Omron's Warranty and Limitations of Liability.

Change in Specifications.

Product specifications and accessories may be changed at any time based on improvements and other reasons. It is our practice to change part numbers when published ratings or features are changed, or when significant construction changes are made. However, some specifications of the Product may be changed without any notice. When in doubt, special part numbers may be assigned to fix or establish key specifications for your application. Please consult with your Omron's representative at any time to confirm actual specifications of purchased Product.

Errors and Omissions.

Information presented by Omron Companies has been checked and is believed to be accurate; however, no responsibility is assumed for clerical, typographical or proofreading errors or omissions.