

## Positioning with Pulse Input Type Motor Drivers Such As Stepper Motor Drive

- The MC Function Modules of the NJ-series Machine Automation Controller enable pulse outputs for motor control.
- The same motion control instructions as those for Servomotor control allow you to program single-axis PTP control and interpolation.



## Features

- When the motion control instructions of the MC Function Modules of the NJ-series Machine Automation Controller are used, number of usable units is the same as the maximum number of axes controlled by the NJ-series Controller.
- Synchronous I/O refreshing with the EtherCAT Coupler Unit.
- Latch function (2 external latch inputs)
- Maximum pulse output speed: 500 kpps

## System Configuration

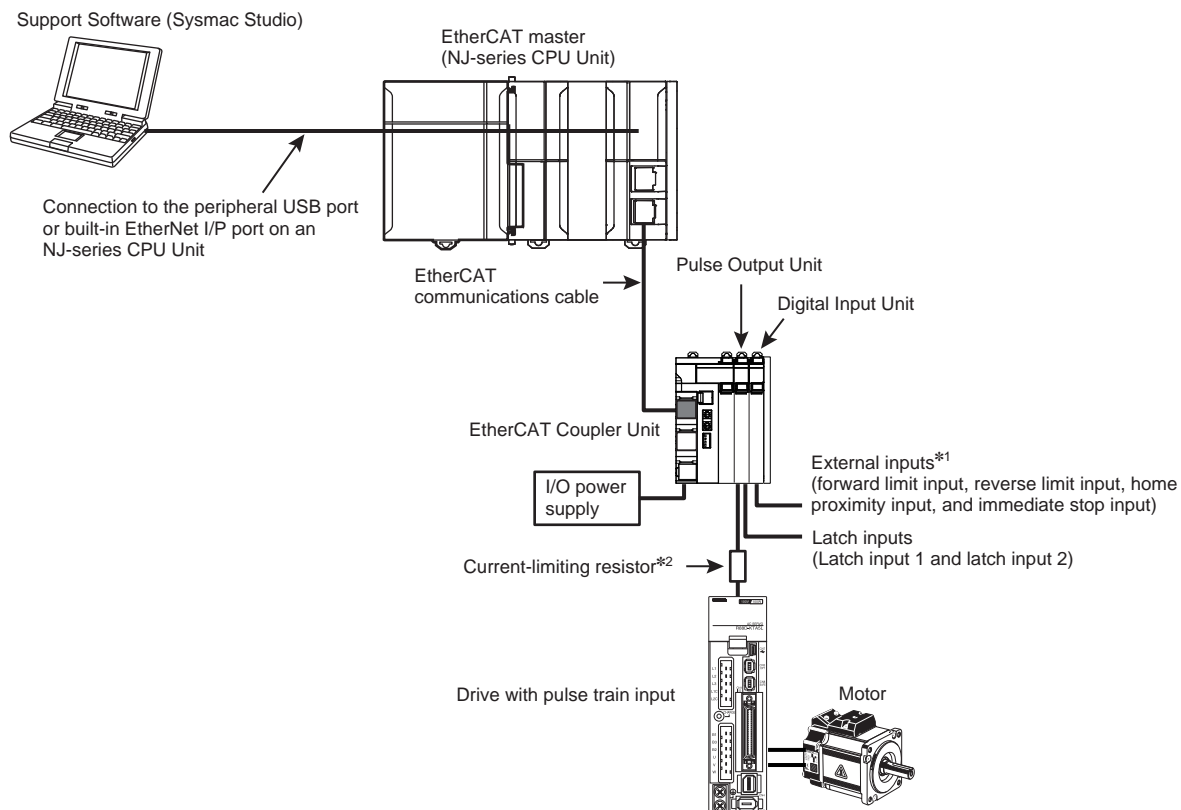

\*1. When the Unit is connected to an NJ-series CPU, you can use these inputs by adding a Digital Input Unit and assigning MC Function Module functions.

\*2. The pulse output from a Pulse Output Unit is a 24-VDC PNP open collector output. Connect an external current-limiting resistor according to the input specifications of the connected motor drive.  
Example: For a G5-series Servo Drive, connect a 2-k $\Omega$  (1/2-W) resistor in series.

Sysmac<sup>®</sup> is a trademark or registered trademark of OMRON Corporation in Japan and other countries for OMRON factory automation products.

EtherCAT<sup>®</sup> is a registered trademark of Beckhoff Automation GmbH for their patented technology. Other company names and product names in this document are the trademarks or registered trademarks of their respective companies.

## Ordering Information

### International Standards

- The standards are abbreviated as follows: U: UL, U1: UL(Class I Division 2 Products for Hazardous Locations), C: CSA, UC: cULus, UC1: cULus (Class I Division 2 Products for Hazardous Locations), CU: cUL, N: NK, L: Lloyd, CE: EC Directives, and KC: KC Registration.
- Contact your OMRON representative for further details and applicable conditions for these standards.

Unit type	Product Name	Specification					Model	Standards
		Number of axes	Pulse Output form	Maximum pulse output speed	I/O signals	Type of external connections		
NX Series Position Interface Unit	Pulse Output Units 	1	Open collector output	500 kpps	External inputs: 2 External outputs: 3	Screwless clamping terminal block (16 terminals)	NX-PG0122	UC1, CE, KC

### Option

Product Name	Specification	Model	Standards
Unit/Terminal Block Coding Pins	For 10 Units (Terminal Block: 30 pins, Unit: 30 pins)	NX-AUX02	–

### Accessories

Not included.

## General Specification

Item		Specification
Enclosure		Mounted in a panel
Grounding method		Ground to less than 100 Ω or less
Operating environment	Ambient operating temperature	0 to 55°C
	Ambient operating humidity	10% to 95% (with no condensation or icing)
	Atmosphere	Must be free from corrosive gases.
	Ambient storage temperature	-25 to 70°C (with no condensation or icing)
	Altitude	2,000 m max.
	Pollution degree	Pollution degree 2 or less: Conforms to JIS B3502 and IEC 61131-2.
	Noise immunity	Conforms to IEC61000-4-4, 2 kV (power supply line)
	Overvoltage category	Category II: Conforms to JIS B3502 and IEC 61131-2.
	EMC immunity level	Zone B
	Vibration resistance	Conforms to IEC 60068-2-6. 5 to 8.4 Hz with 3.5-mm amplitude, 8.4 to 150 Hz, acceleration of 9.8 m/s <sup>2</sup> , 100 min each in X, Y, and Z directions (10 sweeps of 10 min each = 100 min total)
Shock resistance	Conforms to IEC 60068-2-27. 147 m/s <sup>2</sup> , 3 times each in X, Y, and Z directions	
Applicable standards		cULus: Listed UL508 and ANSI/ISA 12.12.01 EC: EN 61131-2 and C-Tick, KC Registration

# Specification

## Pulse Output Units NX-PG0122

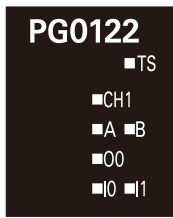
Unit name	Pulse Output Units	Model	NX-PG0122
Number of axes	1	Type of external connections	Screwless clamping terminal block (16 terminals)
I/O refreshing method	Synchronous I/O refreshing *1		
Indicators		I/O signals	External inputs: 2 These are general-purpose inputs. External outputs: 3 These are the forward direction pulse output, reverse direction pulse output, and a general-purpose output.
Control method	Open-loop control through pulse string output		
Controlled drive	Servo drive with a pulse train input or a stepper motor drive		
Pulse output form	Open collector output		
Control unit	Pulses		
Maximum pulse output speed	500 kpps		
Pulse output method	Forward/reverse direction pulse outputs or pulse + direction outputs		
Position control range	-2,147,483,648 to 2,147,483,647 pulses		
Velocity control range	1 to 500,000 pps		
Positioning *2			
Single-axis position control	Absolute positioning, relative positioning, and interrupt feeding		
Single-axis velocity control	Velocity control (velocity feeding in Position Control Mode)		
Single-axis synchronized control	Cam operation and gear operation		
Single-axis manual operation	Jogging		
Auxiliary function for single-axis control	Homing, stopping, and override changes		
External input specifications			
Input voltage	20.4 to 28.8 VDC (24 VDC +20%/–15%)	ON voltage/ON current	15 VDC min./3 mA min.
Input current	4.6 mA typical (24 VDC)	OFF voltage/OFF current	4.0 VDC max./1 mA max.
ON/OFF response time	1 μs max./2 μs max.		
Internal I/O common processing	PNP		
External output specifications			
Rated voltage	24 VDC		
Load voltage range	15 to 28.8 VDC	Residual voltage	1.0 V max.
Maximum load current	30 mA	Leakage current	0.1 mA
ON/OFF response time	5 μs max./5 μs max.		
Internal I/O common processing	PNP		
Dimensions	12 x 100 x 71 mm (WxHxD)	Isolation method	External inputs: Photocoupler isolation External outputs: Digital isolator
Insulation resistance	20 MΩ min. between isolated circuits (at 100 VDC)	Dielectric strength	510 VAC between isolated circuits for 1 minute with leakage current of 5 mA max.
I/O power supply source	Supplied from the NX bus. 20.4 to 28.8 VDC (24 VDC +20%/–15%)	Current capacity of I/O power supply terminals	IOV: 0.1 A max. per terminal IOG: 0.1 A max. per terminal
NX Unit power consumption	0.9 W	Current consumption from I/O power supply	20 mA
Weight	70 g	Cable length	3 m max.

\*1. The I/O refreshing method is automatically set according to the connected Communications Coupler Unit and CPU Unit.

\*2. These functions are supported when you also use the MC Function Module in the NJ-series CPU Unit.

Refer to the NJ-series CPU Unit Motion Control User's Manual (Cat. No. W507) for details.

A Pulse Output Unit only outputs pulses during the control period based on commands received at a fixed period.

Target position calculations (distribution calculations) for acceleration/deceleration control or for each control period must be performed on the Controller that is connected as the host

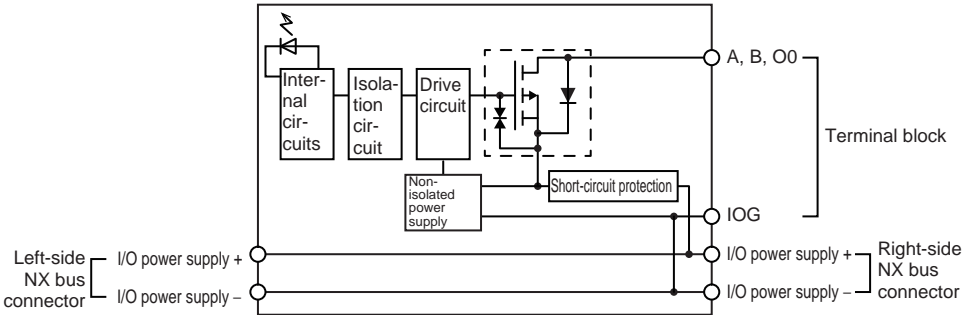
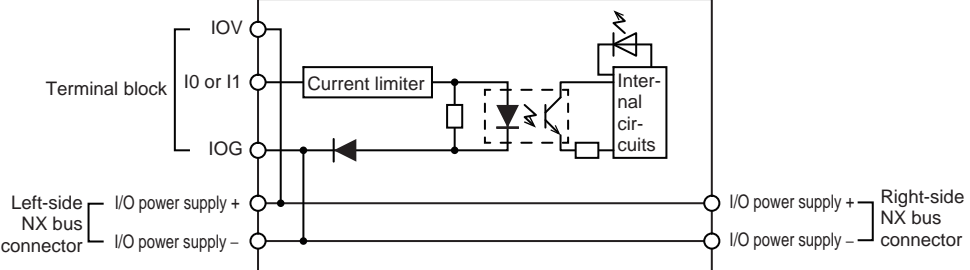
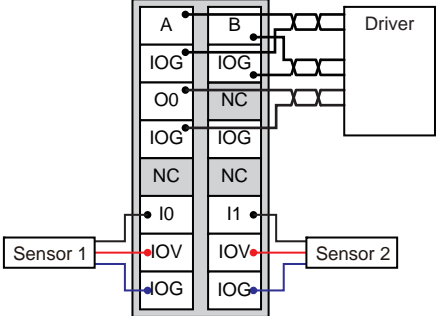
<p><b>Circuit layout</b></p>	<p><b>Pulse Output and External Output</b></p>  <p><b>External Inputs</b></p> 
<p><b>Installation orientation and restrictions</b></p>	<p>Installation orientation: 6 possible orientations Restrictions: There are no restrictions.</p>
<p><b>Terminal connection diagram</b></p>	
<p><b>Failure detection</b></p>	<p>None</p>
	<p><b>Protection</b></p>
	<p>None</p>

## Version Information

### Pulse Output Unit NX Series and Sysmac Studio

Unit NX Series	Sysmac Studio	
	Version 1.05 or lower	Version 1.06 or higher
NX-PG0122	Not supported	Supported

## External Interface

### Pulse Output Unit

NX-PG0122

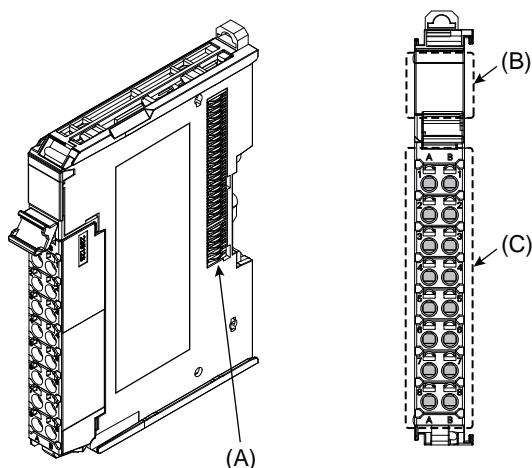

Letter	Item	Specification
(A)	NX bus connector	This connector is used to connect to another Unit.
(B)	Indicators	The indicators show the current operating status of the Unit.
(C)	Terminal block	The terminal block is used to connect to external devices. The number of terminals depends on the Unit.

### Terminal Blocks

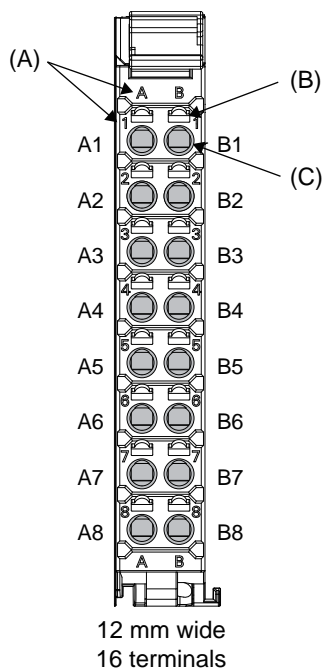

Letter	Item	Specification
(A)	Terminal number indication	The terminal number is identified by a column (A and B) and a row (1 through 8). Therefore, terminal numbers are written as a combination of columns and rows, A1 through A8 and B1 through B8. The terminal number indication is the same regardless of the number of terminals on the terminal block, as shown above.
(B)	Release hole	A flat-blade screwdriver is inserted here to attach and remove the wiring.
(C)	Terminal hole	The wires are inserted into these holes.

## Applicable Wires

### Using Ferrules

If you use ferrules, attach the twisted wires to them.

Observe the application instructions for your ferrules for the wire stripping length when attaching ferrules.

Always use one-pin ferrules. Do not use two-pin ferrules.

The applicable ferrules, wires, and crimping tool are given in the following table.

Terminal types	Manufacturer	Ferrule model	Applicable wire (mm <sup>2</sup> (AWG))	Crimping tool
Terminals other than ground terminals	Phoenix Contact	AI0,34-8	0.34 (#22)	Phoenix Contact (The figure in parentheses is the applicable wire size.) CRIMPFOX 6 (0.25 to 6 mm <sup>2</sup> , AWG 24 to 10)
		AI0,5-8	0.5 (#20)	
		AI0,5-10		
		AI0,75-8	0.75 (#18)	
		AI0,75-10		
		AI1,0-8	1.0 (#18)	
		AI1,0-10		
		AI1,5-8	1.5 (#16)	
Ground terminals	Phoenix Contact	AI1,5-10		
		AI2,5-10	2.0 *1	
Terminals other than ground terminals	Weidmuller	H0.14/12	0.14 (#26)	Weidmuller (The figure in parentheses is the applicable wire size.) PZ6 Roto (0.14 to 6 mm <sup>2</sup> , AWG 26 to 10)
		H0.25/12	0.25 (#24)	
		H0.34/12	0.34 (#22)	
		H0.5/14	0.5 (#20)	
		H0.5/16		
		H0.75/14	0.75 (#18)	
		H0.75/16		
		H1.0/14	1.0 (#18)	
		H1.0/16		
		H1.5/14	1.5 (#16)	
		H1.5/16		

\*1. Some AWG 14 wires exceed 2.0 mm<sup>2</sup> and cannot be used in the screwless clamping terminal block.

When you use any ferrules other than those in the above table, crimp them to the twisted wires so that the following processed dimensions are achieved.

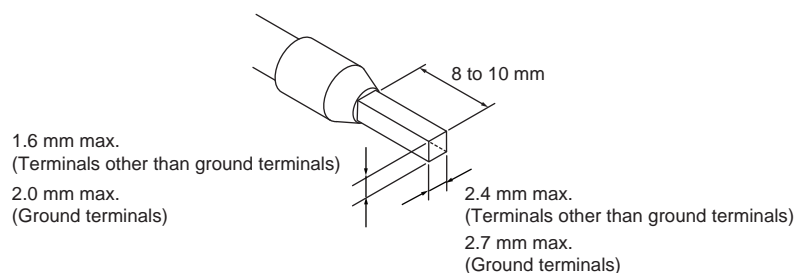

### Using Twisted Wires/Solid Wires

If you use the twisted wires or the solid wires, the applicable wire range and conductor length (stripping length) are as follows.

Use the twisted wires to connect the ground wire to a ground of 100 Ω or less. Do not use the solid wires.

Terminal types	Applicable wires range	Conductor length (stripping length)
Ground terminals	2.0 mm <sup>2</sup>	9 to 10 mm
Terminals other than ground terminals	0.08 to 1.5 mm <sup>2</sup> AWG28 to 16	8 to 10 mm

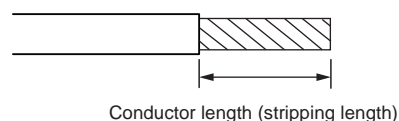



## Dimensions

(Unit: mm)

### Pulse Output Unit NX-PG0122

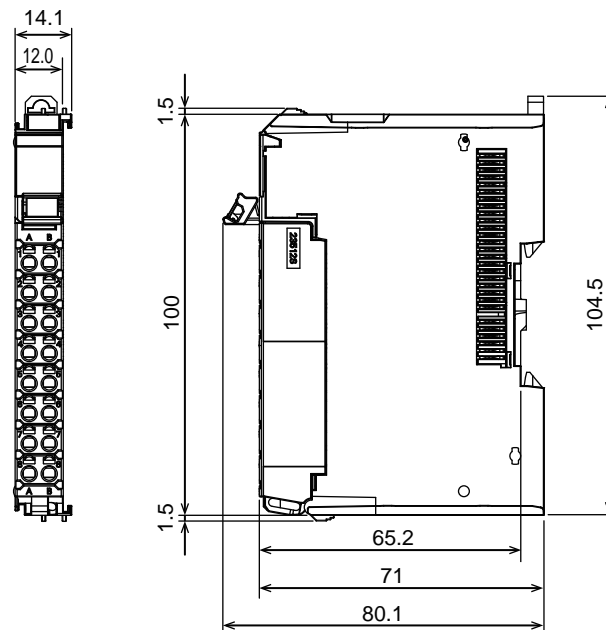

## Related Manuals

Man. No	Model	Manual	Application	Description
W524	NX-EC0□□□ NX-ECS□□□ NX-PG0□□□	NX-series Position Interface Units User's Manual	Learning how to use NX-series Position Interface Units	The hardware, setup methods, and functions of the NX-series Incremental Encoder Input Units, SSI Input Units, and Pulse Output Unit are described.

## Terms and Conditions Agreement

### Read and understand this catalog.

Please read and understand this catalog before purchasing the products. Please consult your OMRON representative if you have any questions or comments.

### Warranties.

(a) Exclusive Warranty. Omron's exclusive warranty is that the Products will be free from defects in materials and workmanship for a period of twelve months from the date of sale by Omron (or such other period expressed in writing by Omron). Omron disclaims all other warranties, express or implied.

(b) Limitations. OMRON MAKES NO WARRANTY OR REPRESENTATION, EXPRESS OR IMPLIED, ABOUT NON-INFRINGEMENT, MERCHANTABILITY OR FITNESS FOR A PARTICULAR PURPOSE OF THE PRODUCTS. BUYER ACKNOWLEDGES THAT IT ALONE HAS DETERMINED THAT THE PRODUCTS WILL SUITABLY MEET THE REQUIREMENTS OF THEIR INTENDED USE.

Omron further disclaims all warranties and responsibility of any type for claims or expenses based on infringement by the Products or otherwise of any intellectual property right. (c) Buyer Remedy. Omron's sole obligation hereunder shall be, at Omron's election, to (i) replace (in the form originally shipped with Buyer responsible for labor charges for removal or replacement thereof) the non-complying Product, (ii) repair the non-complying Product, or (iii) repay or credit Buyer an amount equal to the purchase price of the non-complying Product; provided that in no event shall Omron be responsible for warranty, repair, indemnity or any other claims or expenses regarding the Products unless Omron's analysis confirms that the Products were properly handled, stored, installed and maintained and not subject to contamination, abuse, misuse or inappropriate modification. Return of any Products by Buyer must be approved in writing by Omron before shipment. Omron Companies shall not be liable for the suitability or unsuitability or the results from the use of Products in combination with any electrical or electronic components, circuits, system assemblies or any other materials or substances or environments. Any advice, recommendations or information given orally or in writing, are not to be construed as an amendment or addition to the above warranty.

See <http://www.omron.com/global/> or contact your Omron representative for published information.

### Limitation on Liability; Etc.

OMRON COMPANIES SHALL NOT BE LIABLE FOR SPECIAL, INDIRECT, INCIDENTAL, OR CONSEQUENTIAL DAMAGES, LOSS OF PROFITS OR PRODUCTION OR COMMERCIAL LOSS IN ANY WAY CONNECTED WITH THE PRODUCTS, WHETHER SUCH CLAIM IS BASED IN CONTRACT, WARRANTY, NEGLIGENCE OR STRICT LIABILITY.

Further, in no event shall liability of Omron Companies exceed the individual price of the Product on which liability is asserted.

### Suitability of Use.

Omron Companies shall not be responsible for conformity with any standards, codes or regulations which apply to the combination of the Product in the Buyer's application or use of the Product. At Buyer's request, Omron will provide applicable third party certification documents identifying ratings and limitations of use which apply to the Product. This information by itself is not sufficient for a complete determination of the suitability of the Product in combination with the end product, machine, system, or other application or use. Buyer shall be solely responsible for determining appropriateness of the particular Product with respect to Buyer's application, product or system. Buyer shall take application responsibility in all cases.

NEVER USE THE PRODUCT FOR AN APPLICATION INVOLVING SERIOUS RISK TO LIFE OR PROPERTY OR IN LARGE QUANTITIES WITHOUT ENSURING THAT THE SYSTEM AS A WHOLE HAS BEEN DESIGNED TO ADDRESS THE RISKS, AND THAT THE OMRON PRODUCT(S) IS PROPERLY RATED AND INSTALLED FOR THE INTENDED USE WITHIN THE OVERALL EQUIPMENT OR SYSTEM.

### Programmable Products.

Omron Companies shall not be responsible for the user's programming of a programmable Product, or any consequence thereof.

### Performance Data.

Data presented in Omron Company websites, catalogs and other materials is provided as a guide for the user in determining suitability and does not constitute a warranty. It may represent the result of Omron's test conditions, and the user must correlate it to actual application requirements. Actual performance is subject to the Omron's Warranty and Limitations of Liability.

### Change in Specifications.

Product specifications and accessories may be changed at any time based on improvements and other reasons. It is our practice to change part numbers when published ratings or features are changed, or when significant construction changes are made. However, some specifications of the Product may be changed without any notice. When in doubt, special part numbers may be assigned to fix or establish key specifications for your application. Please consult with your Omron's representative at any time to confirm actual specifications of purchased Product.

### Errors and Omissions.

Information presented by Omron Companies has been checked and is believed to be accurate; however, no responsibility is assumed for clerical, typographical or proofreading errors or omissions.